

THE SANDMINION

BY SPEARHEAD SAND INC.

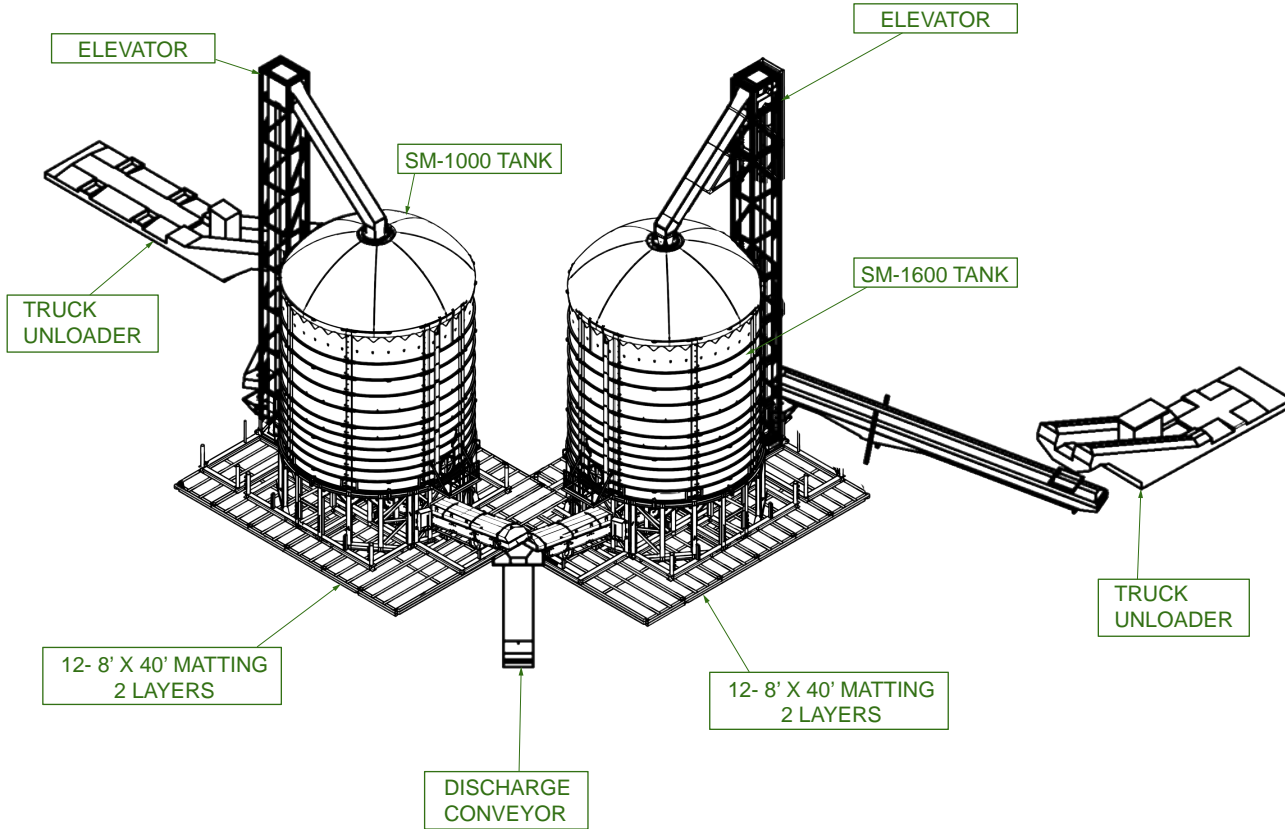

SPECS

CAPACITY	TONNE	TON (US)
	2600	2860
DIMENSIONS	METER	FT
	OVERALL LENGTH	66
OVERALL WIDTH	27	88
TANK HEIGHT	32	106
ELEVATOR HEIGHT	44	144
WEIGHTS	KG	LBS
	TANK PANNELS	39'500
CENTER HOPPER MOD	39'800	88'000
SIDE HOPPER MODS	23'100	51'000
ELEVATOR	25'100	55'000
TRUCK UNLOADER	27'200	60'000
TANK ASSEMBLY FULL	2'740'600	6'042'000
SHIPPING	TRUCK LOADS	
HOPPER	6	
TANK PANELS	2	
ELEVATOR	2	
TRUCK UNLOADER	2	
CONEYOR SPEEDS	TPH	TPH (US)
	TRUCK UNLOADER	330
ELEVATOR	330	364
DISCHARGE CONVEYOR	40-400 x2	44-440 x2



DRAWN BY	SHEA LAYDEN
DATE DRAWN	07/12/2023
LAST CHANGED	07/12/2023



SHEET 1 OF 1	SCALE
<small>THE INFORMATION AND SPECIFICATIONS CONTAINED IN THIS DRAWING ARE THE PROPERTY OF SPEARHEAD SAND INC. AND THE PROPRIETARY MANUFACTURING METHOD OF SPEARHEAD SAND INC. NO PART OF THIS DRAWING OR THE INFORMATION CONTAINED HEREIN MAY BE REPRODUCED OR TRANSMITTED IN ANY FORM OR BY ANY MEANS, WITHOUT THE WRITTEN PERMISSION OF SPEARHEAD SAND INC.</small>	

PART NO.	SM-2600-GA
SPECS	

VERY FLEXIBLE AND CONFIGURABLE / SUPER SMALL FOOTPRINT

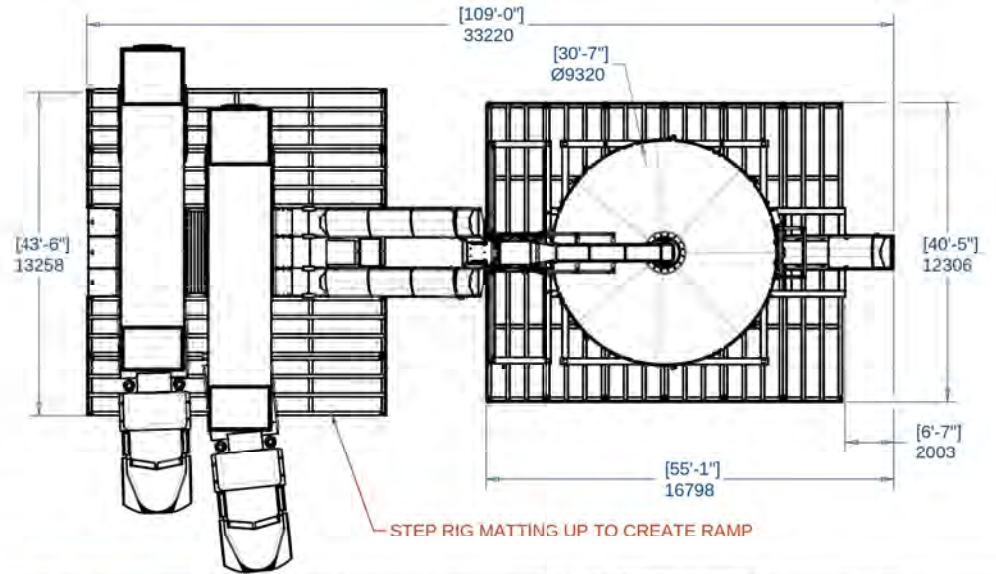
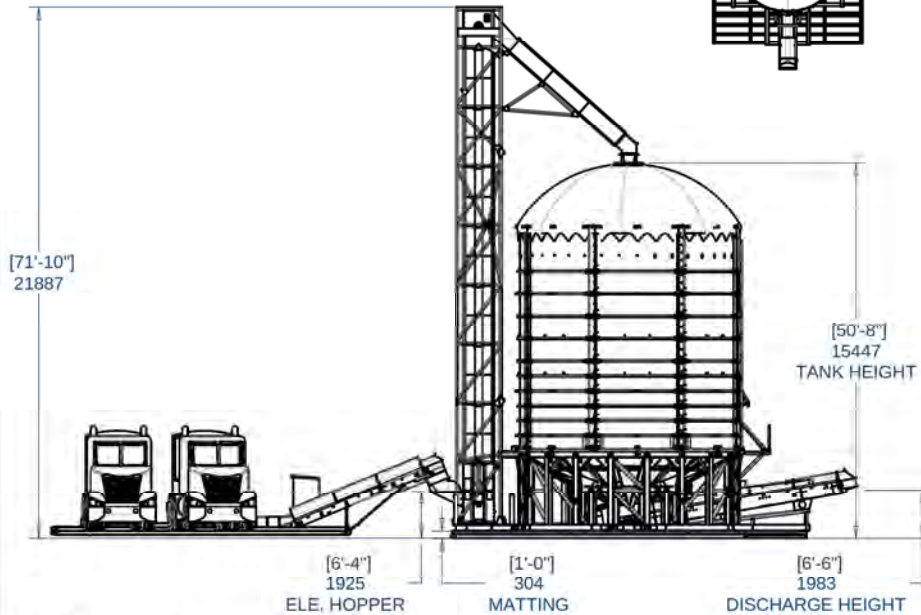
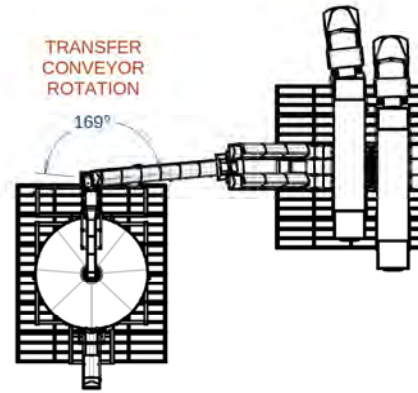
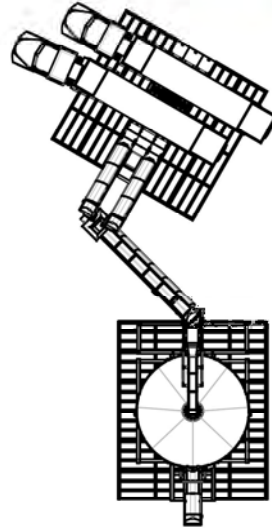
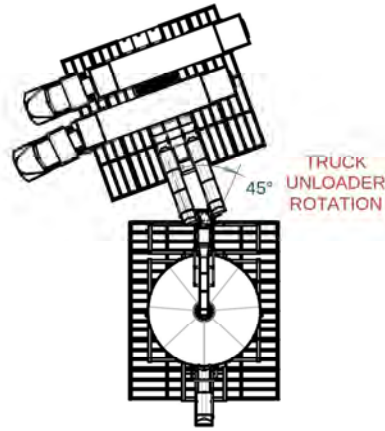

THE SANDMINION
BY SPEARHEAD SAND INC.



DRAWN BY	SHEA LAYDEN
DATE DRAWN	07/17/2022
LAST CHANGED	10/20/2022



SHEET 3 OF 1 SCALE: 1:200

THE SANDMINION AND SPEARHEAD SAND INC. ARE TRADEMARKS OF SPEARHEAD SAND INC. ALL RIGHTS RESERVED. THE SANDMINION IS A REGISTERED SERVICE MARK OF SPEARHEAD SAND INC. THE SANDMINION IS A REGISTERED SERVICE MARK OF SPEARHEAD SAND INC. THE SANDMINION IS A REGISTERED SERVICE MARK OF SPEARHEAD SAND INC.

PART NO.

SM-2600-GA

LAYOUT

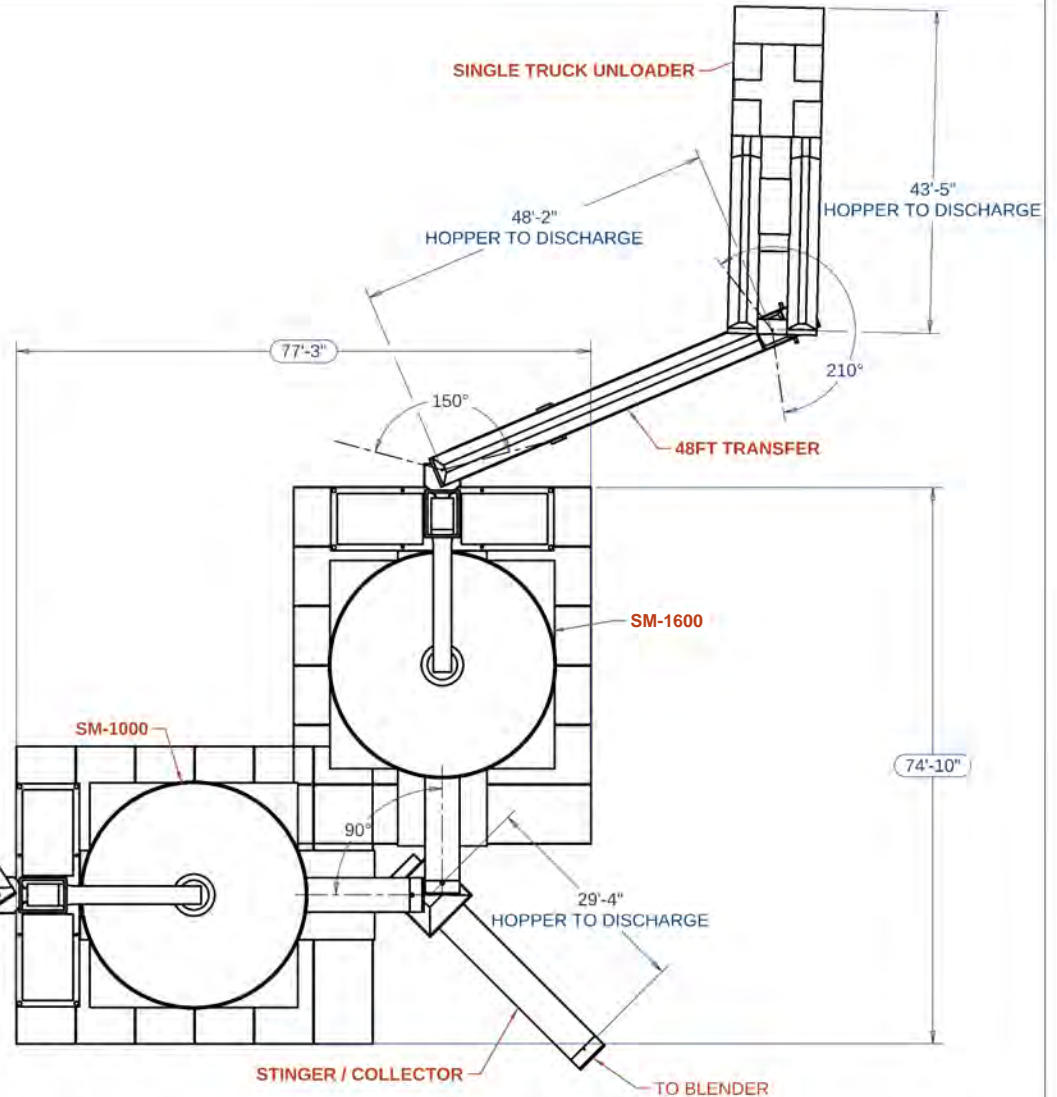
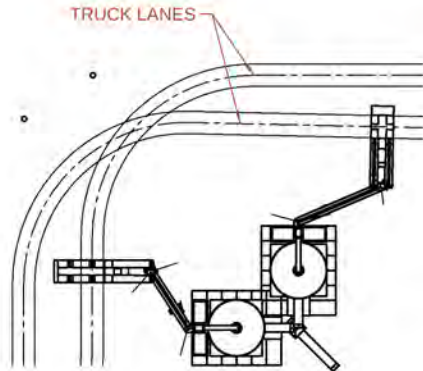
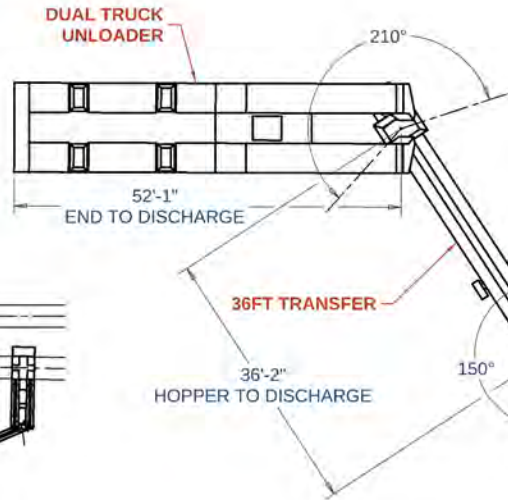
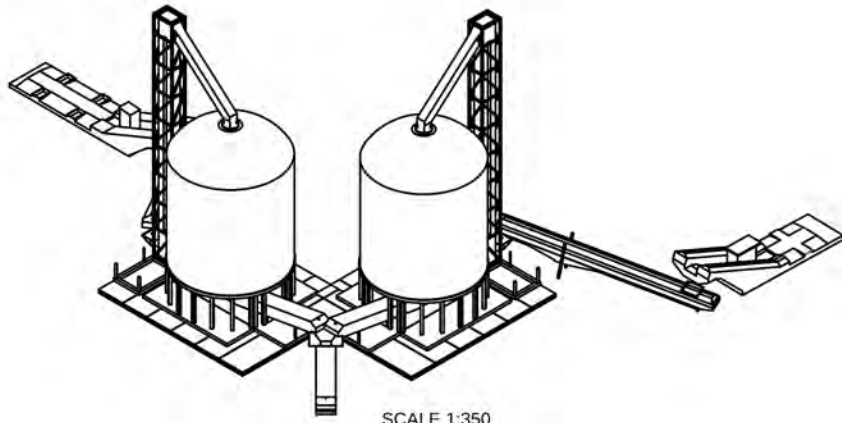

DRAWN BY SHEA LAYDEN
 DATE DRAWN 03/28/2023
 LAST CHANGED 04/17/2023



SHEET 1 OF 2 SCALE 1:800

PART NO.
SM-1000X1600-90

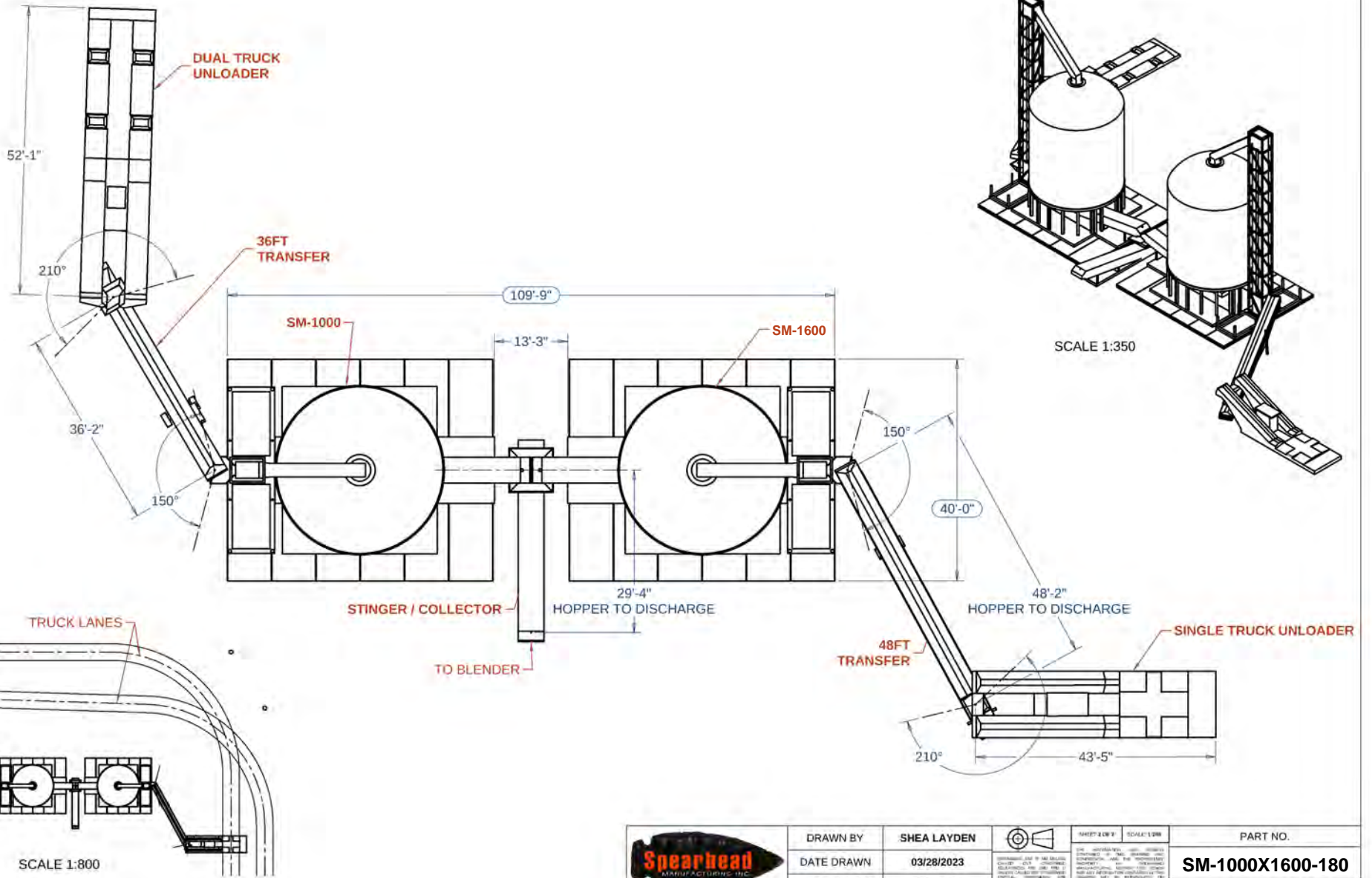

DRAWN BY	SHEA LAYDEN		DATE DRAWN	03/28/2023	SCALE 1:350
DATE DRAWN	03/28/2023		LAST CHANGED	04/12/2023	
LAST CHANGED	04/12/2023				

PART NO.	SM-1000X1600-180
----------	------------------

REV	DESCRIPTION
	INITIAL RELEASE

GROUND WORK PREPERATION
 SAND MINION MUST BE SET UP ON SOLID
 LEVEL GROUND, DO NOT USE FALSE FILL,
 ALL MATERIALS TO LEVEL PAD MUST BE
 COMPACTED TO 400KPA OR NON
 CAMPACTABLE MATERIALS SUCH AS
 WASHED ROCK

MATTING LAYOUT AND GROUND WORK PREP

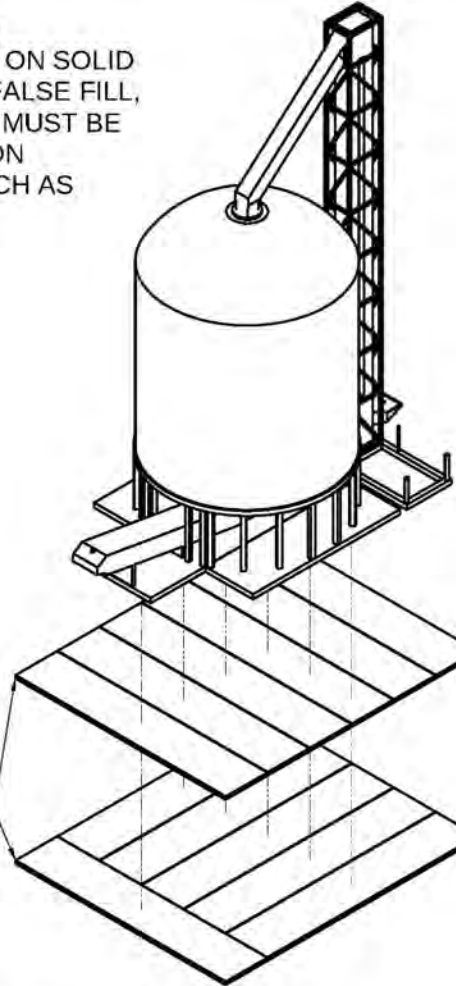

MATTING STACKED IN THE
 SAME DIRECTION
 MUST BE INSTALLED UNDER
 DISCHARGE CONVEYOR
 END.

BOTTOM
 LAYER

12 - 8' X 40' MATTING REQUIRED
 FOR TANK BASE

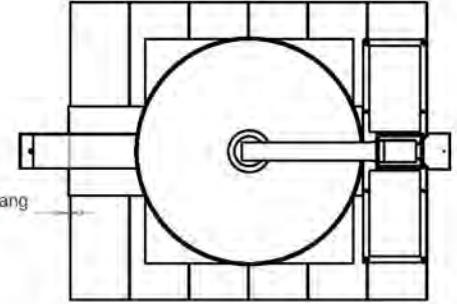

3" Skid must overhang
 rig mats.

SCALE 1:200

TOP LAYER OF MATTING DIRECTLY
 UNDER TANK AND ELEVATOR MUST
 BE INSTALLED PERPENDICULAR TO
 BOTTOM LAYER AND TANK SKIDS

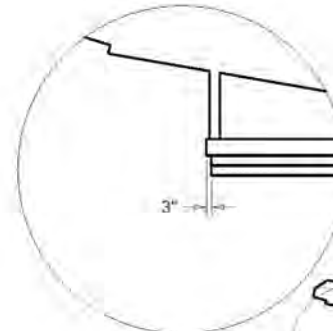

DETAIL A
 SCALE 1:75

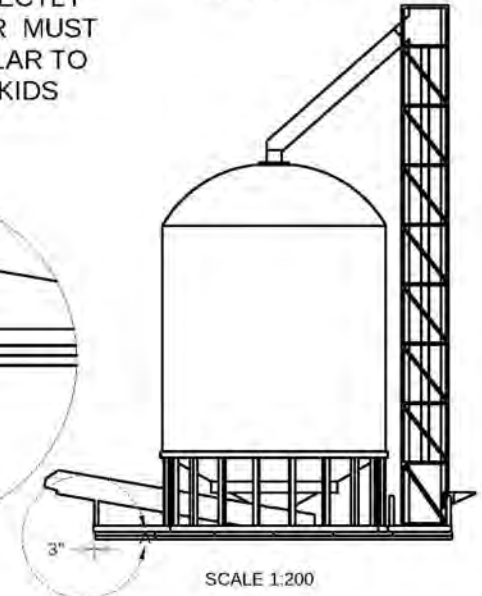

3"

SCALE 1:200



DRAWN BY	SHEA LAYDEN		SHEET 1 OF 3	SCALE 1:100	PART NO.
DATE DRAWN	02/09/2023		<small> THE INFORMATION ON THIS DRAWING IS THE PROPERTY OF SPEARHEAD SAND. IT IS TO BE USED ONLY FOR THE PROJECT AND LOCATION SPECIFICALLY IDENTIFIED ON THIS DRAWING. IT IS NOT TO BE REPRODUCED, COPIED, OR TRANSMITTED IN ANY FORM OR BY ANY MEANS, ELECTRONIC OR MECHANICAL, INCLUDING PHOTOCOPYING, RECORDING, OR BY ANY INFORMATION STORAGE AND RETRIEVAL SYSTEM, WITHOUT THE WRITTEN PERMISSION OF SPEARHEAD SAND. </small>		SM-2600-MATTING
LAST CHANGED	02/15/2023				

REV	DESCRIPTION
	INITIAL RELEASE

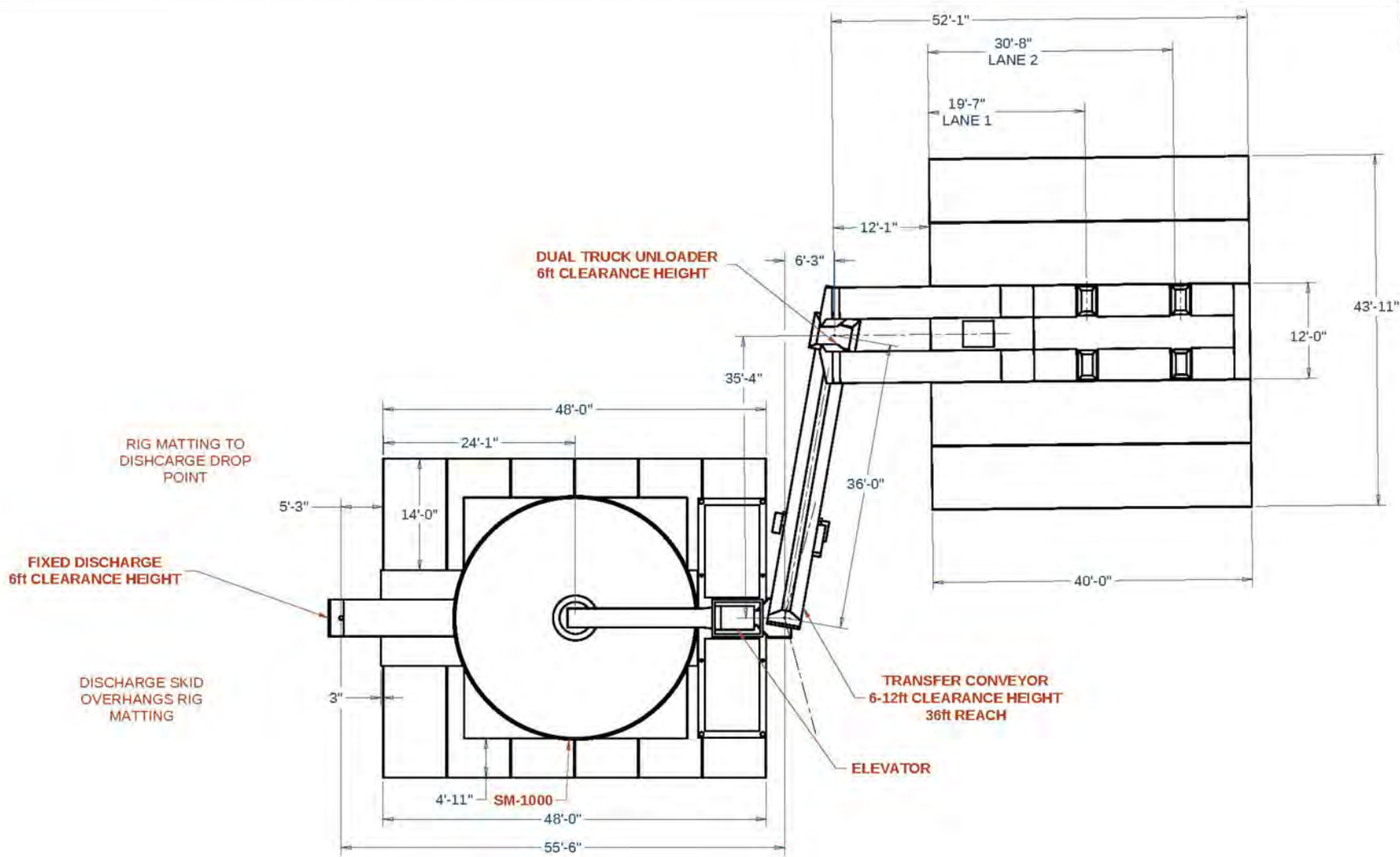

DRAWN BY	SHEA LAYDEN
DATE DRAWN	12/13/2022
LAST CHANGED	03/03/2023



SHEET 1 OF 1	SCALE 1:100
--------------	-------------

PART NO.	TU-TC36-SM26K
	SM-2600-LATOUT-C

THESE DIMENSIONS ARE IN INCH UNLESS OTHERWISE NOTED. THE DRAWING AND DIMENSIONS ARE THE PROPERTY OF SPEARHEAD SAND AND SHALL REMAIN THE PROPERTY OF SPEARHEAD SAND. NO PART OF THIS DRAWING IS TO BE REPRODUCED OR TRANSMITTED IN ANY FORM OR BY ANY MEANS, ELECTRONIC OR MECHANICAL, INCLUDING PHOTOCOPYING, RECORDING, OR BY ANY INFORMATION STORAGE AND RETRIEVAL SYSTEM, WITHOUT THE WRITTEN PERMISSION OF SPEARHEAD SAND.

REV	DESCRIPTION
	INITIAL RELEASE

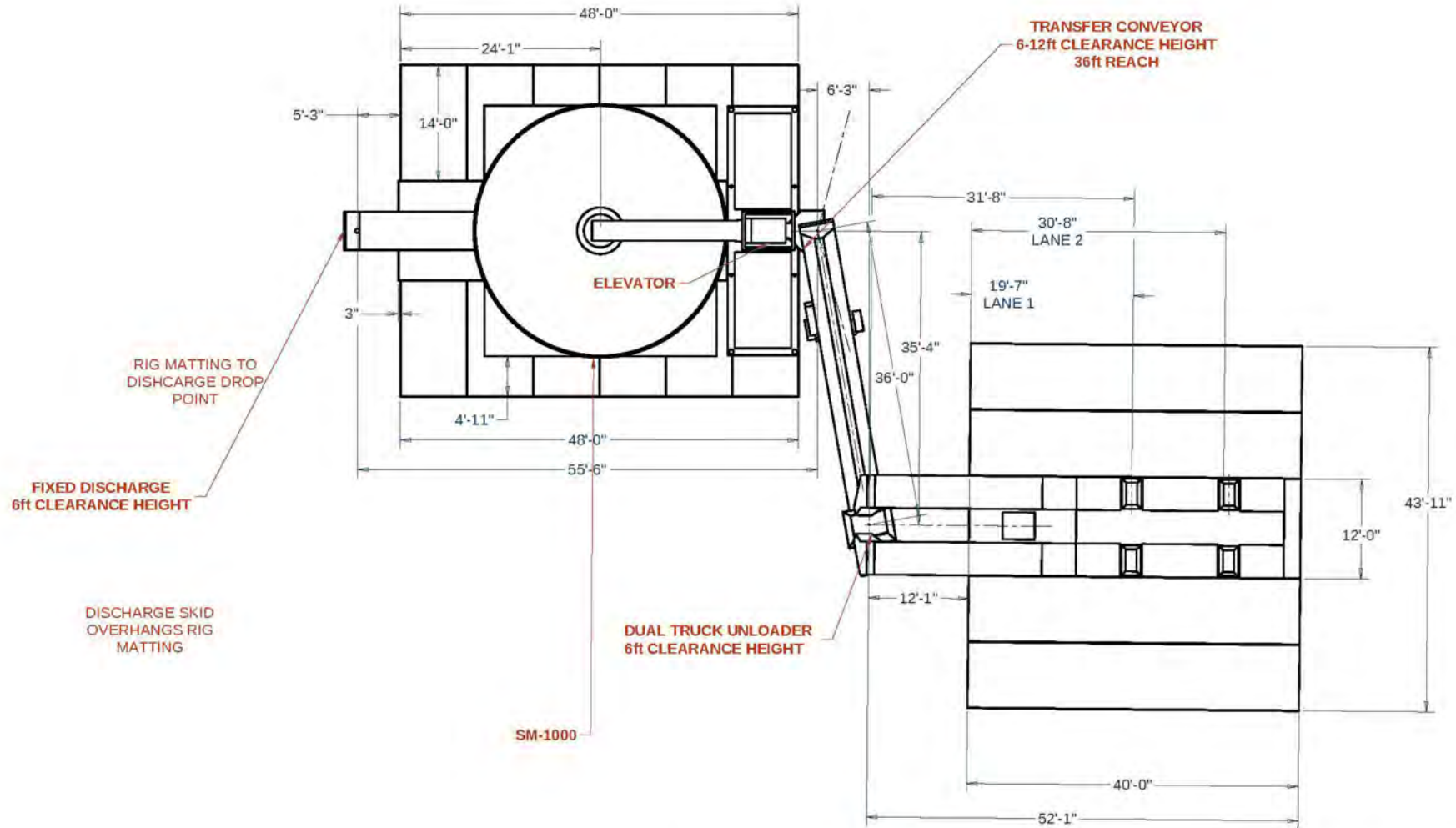

DRAWN BY	MONTE H		SHEET 1 OF 1 SCALE 1:500	PART NO.
DATE DRAWN	02/15/2023			TU-TC36-SM26K
LAST CHANGED	03/03/2023			SM-2600-LATOUT-C

REV	DESCRIPTION
	INITIAL RELEASE

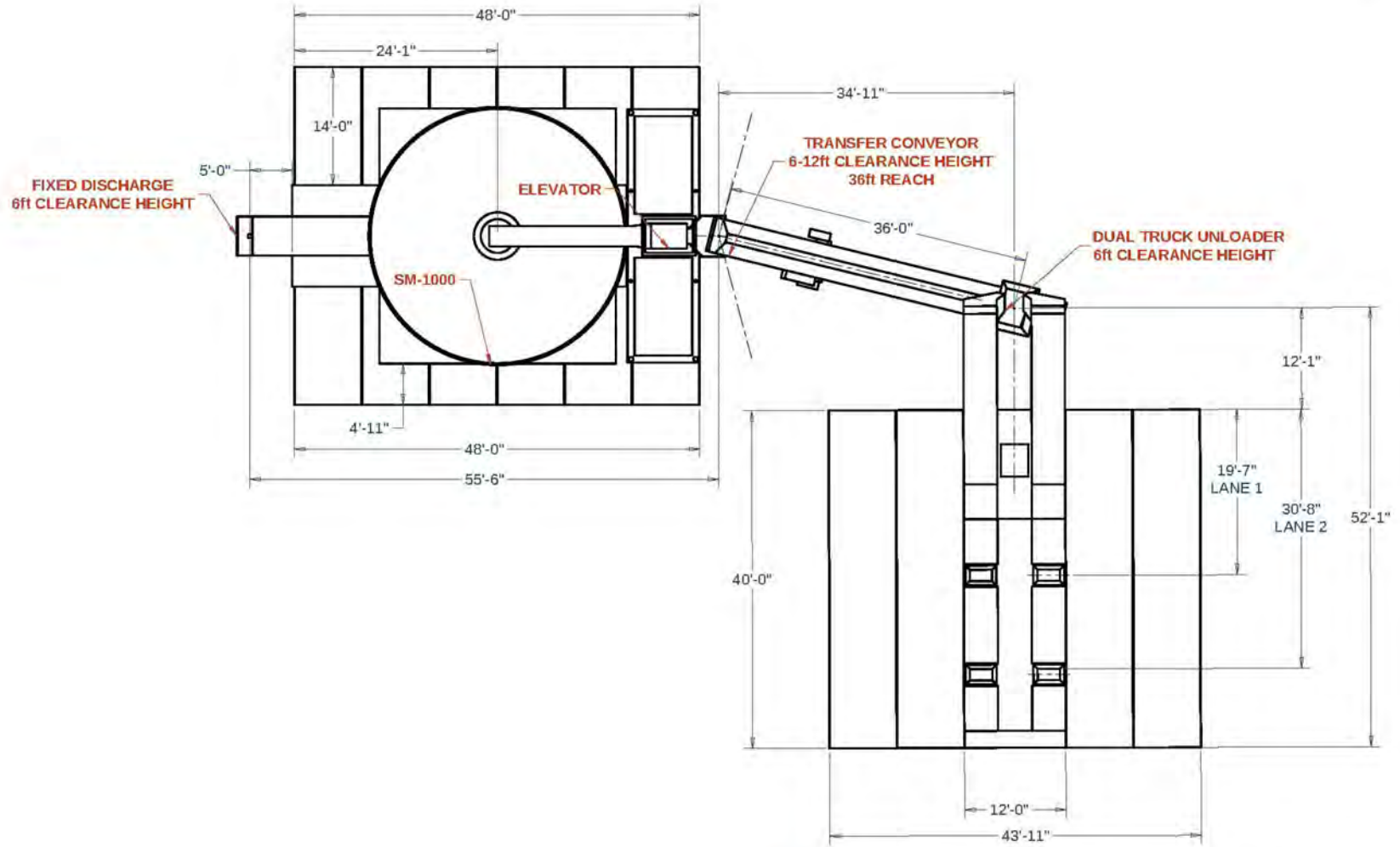

DRAWN BY	MONTE H
DATE DRAWN	02/15/2023
LAST CHANGED	02/15/2023



SHEET 00FL	SCALE 1:50
------------	------------

PART NO.	TU-TC36-SM26K
	SM-2600-LAYOUT-C

THE INFORMATION ON THIS SHEET IS THE PROPERTY OF SPEARHEAD SAND. IT IS TO BE USED ONLY FOR THE PROJECT AND SITE SPECIFICALLY IDENTIFIED HEREON. NO PART OF THIS SHEET IS TO BE REPRODUCED OR TRANSMITTED IN ANY FORM OR BY ANY MEANS, ELECTRONIC OR MECHANICAL, INCLUDING PHOTOCOPYING, RECORDING, OR BY ANY INFORMATION STORAGE AND RETRIEVAL SYSTEM.